

GAS X1CE F - GAS X2CE F - GAS X3CE F - GAS X4CE F - GAS X5CE F

Gas burners one stage with: die-cast aluminum body, fan at high pressurisation, combustion head with adjustment at high efficiency and high flame stability and protection cover in steel and specific features for the application on industrial ovens and bakery ovens.

Compact overall dimensions and disposition rationalized of the components with accessibility facilitated for the operations of setting and maintenance.

Available in the versions METHANE (natural gas) or G.P.L. (to specify at the order) on demand specific versions for town gas, coal gas or biogas.

Gas train completely assembled, electrically linked and tested; complete of working valve with flow adjustment, safety valve, minimum gas pressure switch and stabiliser filter of gas pressure.

Complete of connector plug / socket 7 poles, flange and gasket for installation on ovens.



Fig. 1 GAS X2CE F

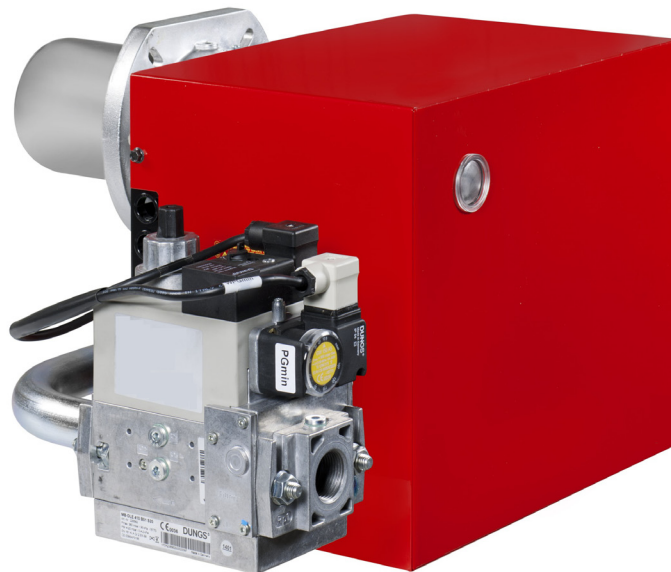

Fig. 2 GAS X3CE F

TECHNICAL DATA AND OPERATING RANGE DIAGRAM

MODEL		GAS X1CE F	GAS X2CE F	GAS X3CE F	GAS X4CE F	GAS X5CE F
Thermal power min. - max. *	[Mcal/h]	20-50	35-80	60-150	100-200	130-300
Thermal power min. - max. *	[kW]	23.2-58.1	40.7-93	69.8-174	116-232	151-349
Gas flow G20 (NATURAL GAS) min. - max. *	[Nm³/h]	2.3-5.8	4.1-9.4	7-17.5	11.7-23.4	15.2-35.1
Gas flow G31 (L.P.G.) min. - max. *	[Nm³/h]	0.9-2.2	1.6-3.6	2.7-6.8	4.5-9	5.8-13.5
Fuel: NATURAL GAS (second family) - L.P.G. (third family)						
Fuel category:		I2R,I2H,I2L,I2E,I2E+,I2Er,I2ELL,I2E(R) / I3B/P,I3+,I3P,I3B,I3R				
Intermittent working operation (min. 1 stop every 24 hours) one stage						
Environmental conditions operation / storage:		-15...+40°C / -20...+70°C, rel. humidity max. 80%				
Max. temperature combustion air	[°C]	60	60	60	60	60
Min. pressure gas train D1/2"-S NATURAL GAS/L.P.G. **	[mbar]	14/31	-	-	-	-
Min. pressure gas train D3/4"-S NATURAL GAS/L.P.G. **	[mbar]	-	18/24	-	-	-
Min. pressure gas train D1"-S NATURAL GAS/L.P.G. **	[mbar]	-	-	14/31	14/21	27/33
Min. pressure gas train D1"1/4-S NATURAL GAS/L.P.G. **	[mbar]	-	-	-	-	16/25
Max. pressure at the entry of valves (Pe. max)	[mbar]	60	360	360	360	360
Nominal electric power	[W]	110	130	200	226	540
Fan motor	[W]	75	75	110	200	370
Nominal motor current absorption	[A]	0.6	0.6	0.9	1.1	2.4
Power supply:		1/N~230V-50Hz				
Electric protection degree:		IP 40	IP 40	IP 40	IP 40	IP 40
Noisiness *** min. - max.	[dB(A)]	59-60	60-61	64-66	64-66	67-71
Burner weight	[kg]	16	16	17	19	29

* Reference conditions: Environment temperature 20°C - Barometric pressure 1013 mbars - Altitude 0 metre (sea level).

** Minimal feeding-gas pressure to the gas train to get the maximum power of the burner, considering counter-pressure in combustion chamber of value 0 (zero).

*** Measured sonorous pressure in the laboratory combustion, with functional burner on beta boiler to 1 metre of distance (UNI EN ISO 3746 law).

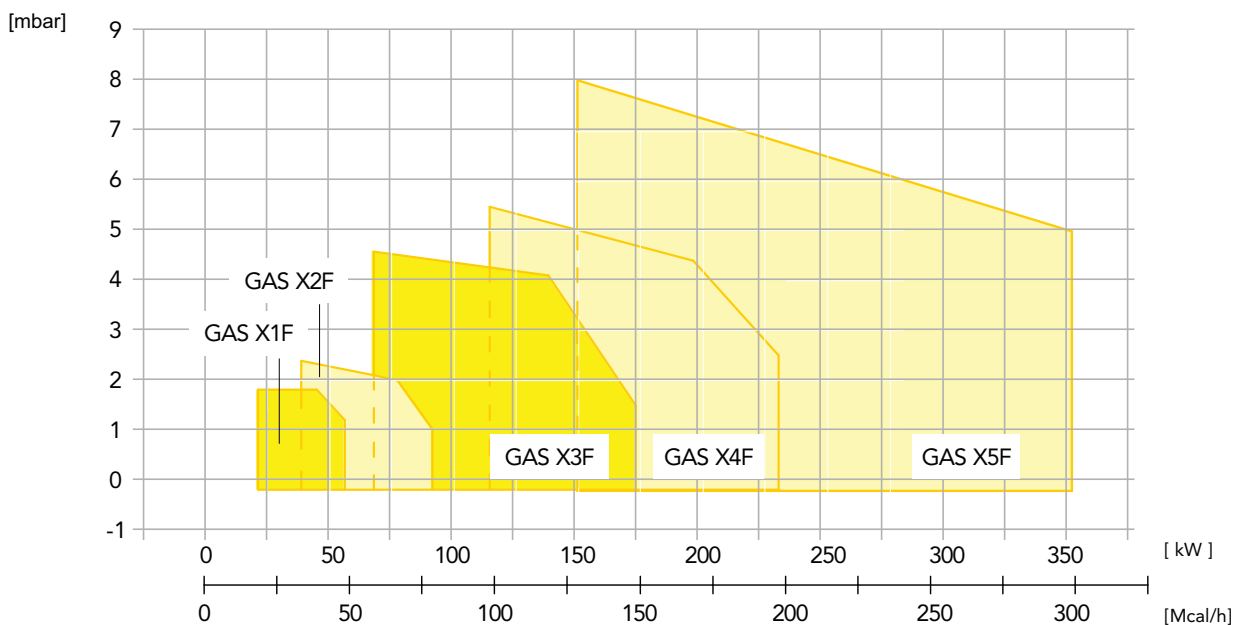

Fig. 3 X = Thermal power Y = Pression in the combustion chamber

The firing rates has been obtained based on test boilers in accordance with EN267 standards and are indicative of matching the burner to the boiler. For the correct operation of the burner, combustion chamber dimensions must be in accordance with current regulation. In case of non-compliance, contact the manufacturer.

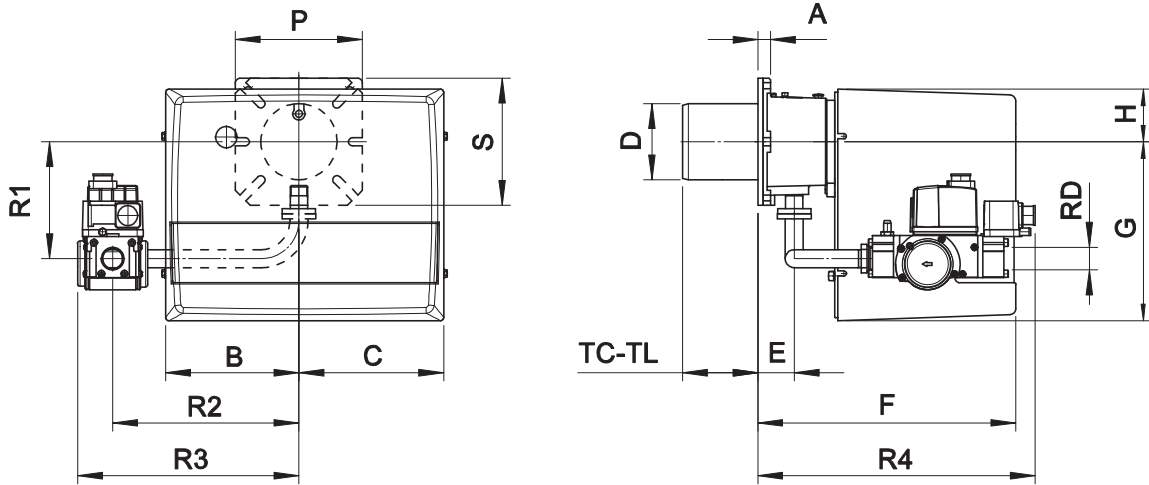

Fig. 4 Dimensions GAS X1CE F - GAS X2CE F - GAS X3CE F - GAS X4CE F

MODEL	A	B	C	D	E	F	G	H	P	S	TC	TL *	R1	R2	R3	R4	RD	Gas train weight
GAS X1CE F D1/2"-S	15	162	175	90	43	305	210	65	150	150	90	150	132	200	254	240	Rp 1/2	2 kg
GAS X2CE F D3/4"-S	15	162	175	90	43	305	210	65	150	150	90	150	138	220	262	328	Rp 3/4	3 kg
GAS X3CE F D1"-S	16	185	195	108	54	340	248	70	200	160	130	250	168	280	337	361	Rp 1	8 kg
GAS X4CE F D1"-S	20	185	195	125	78	368	248	70	200	200	160	280	173	280	337	385	Rp 1	8 kg

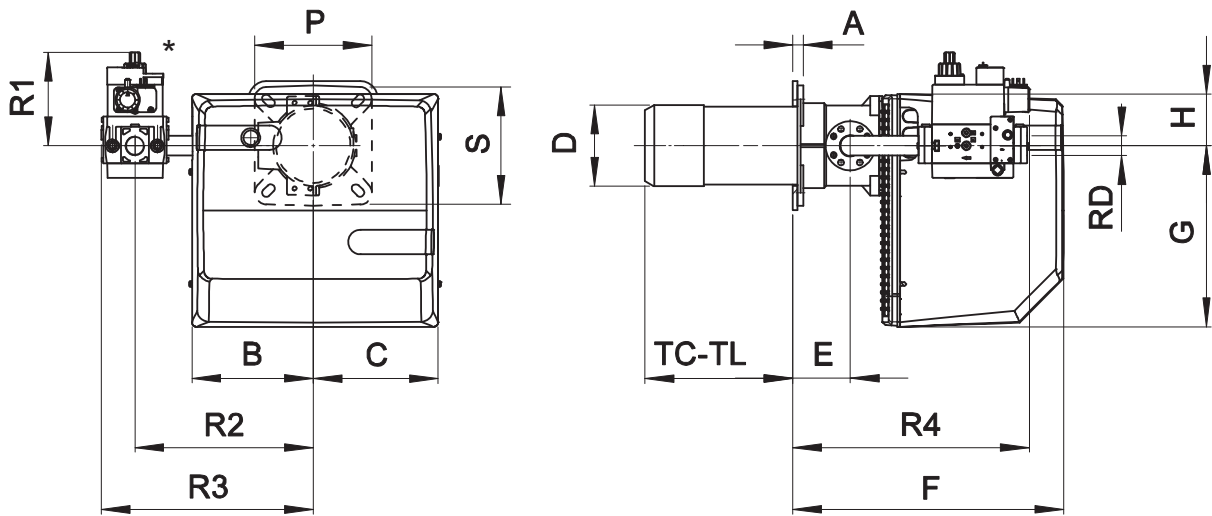
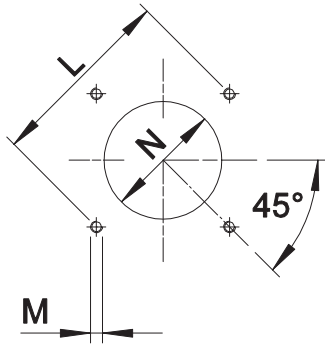

Fig. 5 Dimensions GAS X5CE F

MODEL	A	B	C	D	E	F	G	H	P	S	TC	TL *	R1	R2	R3	R4	RD	Gas train weight
GAS X5CE F D1"-S	18	207	213	138	98	462	310	90	200	200	250	335	160	305	362	403	Rp 1	8 kg
GAS X5CE F CT-D1"-S	18	207	213	138	98	462	310	90	200	200	250	335	160	305	480	403	Rp 1	9 kg
GAS X5CE F D1"1/4-S	18	207	213	138	98	462	310	90	200	200	250	335	160	305	362	450	Rp 1 1/4	8 kg
GAS X5CE F CT-D1"1/4-S	18	207	213	138	98	462	310	90	200	200	250	335	160	305	480	450	Rp 1 1/4	9 kg

* For different flame lengths, please contact our Technical-Sales Department.



** Suggested dimension of connection between burner and generator.

Fig. 6 Boiler plate

MODEL		L min	L **	L max	M	N min	N **	N max
GAS X1CE F	mm	130	150	170	M8	100	110	130
GAS X2CE F	mm	130	150	170	M8	100	110	130
GAS X3CE F	mm	150	170	170	M8	120	130	140
GAS X4CE F	mm	170	205	226	M10	130	140	160
GAS X5CE F	mm	205	226	226	M10	150	150	180

PRODUCT SPECIFICATION**SHORT DESCRIPTION**

Gas burners one stage for bakery ovens.

DETAILED SPECIFICATION

Gas burner one stage for bakery ovens composed by:

- Die-cast aluminum body;
- Fan at high pressurisation;
- Combustion head with adjustment at high performance and elevated flame stability equipped with inox steel blast tube and steel flame disc;
- Protection cover in steel;
- Specific features for the application on industrial ovens and bakery ovens;
- Flange and insulating gasket for fixing on ovens;
- Single-phase power supply;
- Safety air pressure switch to stop the burner in case of failed or anomalous fan operation;
- Gas train with safety valve and adjustment valve;
- Ionisation probe for flame detection;
- IP 40 electric protection level.

CONFORMING TO:

- CE rules;
- 2014/30/UE Directive E.M.C.;
- 2014/35/UE Directive L.V.;
- 2006/42/CE - 2006/42/EG - 2006/42/EC Directive M.D.;
- GAS 2016/426/UE Regulation;
- Reference rules: EN676 (gas) – EN 746-2 (industrial thermoprocessing equipment).

STANDARD EQUIPMENT

- Isomart gasket;
- Flange with insulating gasket;
- Burner nameplate;
- Warranty;
- Instruction handbook for installation, use and maintenance.

OPTIONAL

- Antivibration couplings;
- Handle gas taps.