

FGP 350/M - FGP 450/M - FGP 550/M

Burners for light-oil two stages progressive (hi-low flame) or modulating (PID fully modulating) if equipped with addition of optional modulation kit and probe.

They are composed by: fan at high pressurisation and combustion head with adjustment at high efficiency and high flame stability.

Compact overall dimensions and disposition rationalized of the components with accessibility facilitated for the operations of setting and maintenance.

Complete of nozzle, flexible pipes and line filter.

Complete of flange and gasket for installation on generator.



Available with mechanical cam or with electronic cam.

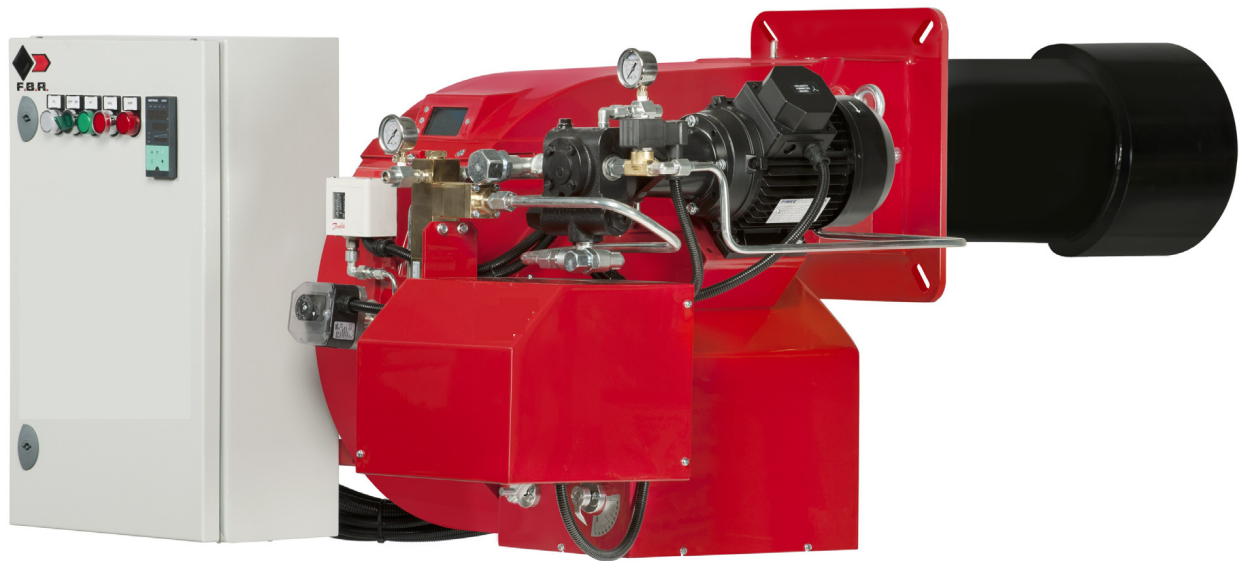

Fig. 1

TECHNICAL DATA FGP 350/M - FGP 450/M - FGP 550/M

MODEL		FGP 350/M	FGP 450/M	FGP 550/M
Flow 1st stage / min. 2nd stage - max. 2nd stage *	[kg/h]	46/140-350	53/160-450	66/200-550
Thermal power 1st stage / min. 2nd stage - max. 2nd stage *	[Mcal/h]	460/1400-3500	530/1600-4500	660/2000-5500
Thermal power 1st stage / min. 2nd stage - max. 2nd stage *	[kW]	534/1660-4151	615/1898-5337	766/2372-6523
Fuel: LIGHT-OIL 1.5°E at 20°C = 6.2 cSt = 35 sec Redwood N°1				
Intermittent working operation (min. 1 stop every 24 hours) two stages progressive or modulating				
Environmental conditions operation / storage:	-15...+40°C / -20...+70°C, rel. humidity max. 80%			
Max. temperature combustion air	[°C]	60	60	60
Nominal electric power	[kW]	12	14	21
Fan motor	[kW]	9	11	18.5
Pump motor	[kW]	2.2	2.2	2.2
Nominal motor current absorption	[A]	19	21.7	36
Nominal auxiliary absorption	[A]	0.6	0.6	0.6
Power supply:	3~400V, 1N~230V - 50Hz			
Electric protection degree:		IP 40	IP 40	IP 40
Noisiness ** min. - max.	[dB(A)]	86-86	88-89	89-90
Burner weight	[kg]	230	240	287

* Reference conditions: Environment temperature 20°C - Barometric pressure 1013 mbars - Altitude 0 metre (sea level).

** Measured sonorous pressure in the combustion lab, with functional burner on beta boiler in a distance of 1 m (UNI EN ISO 3746).

OPERATING RANGE DIAGRAM FGP 350/M - FGP 450/M - FGP 550/M

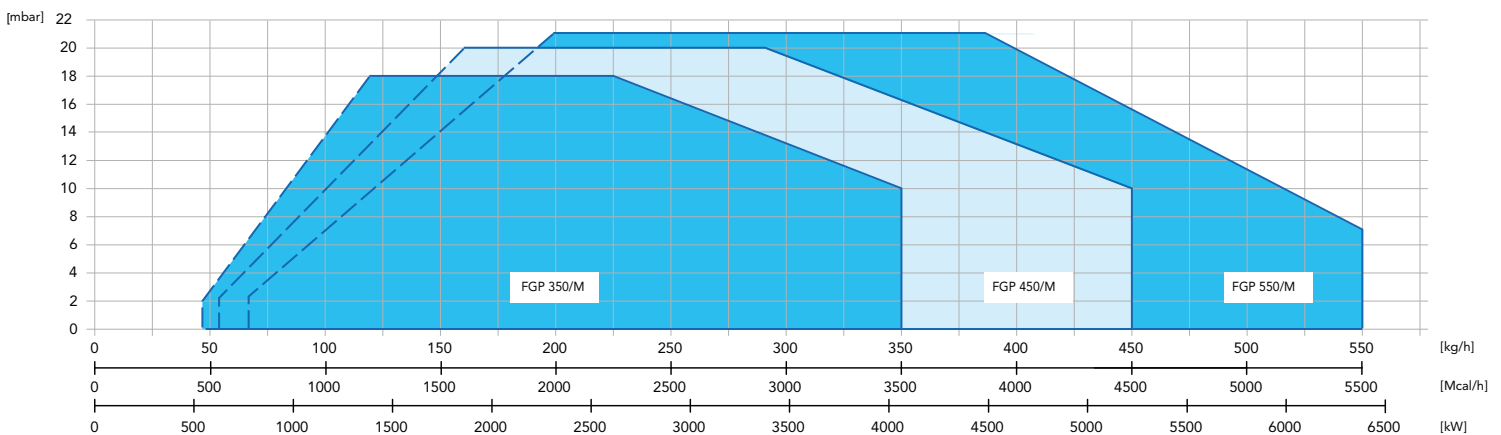

Fig. 2 X = Thermal power Y = Pression in the combustion chamber

The firing rates has been obtained based on test boilers in accordance with EN267 standards and are indicative of matching the burner to the boiler. For the correct operation of the burner, combustion chamber dimensions must be in accordance with current regulation. In case of non-compliance, contact the manufacturer.

DIMENSIONS [MM]

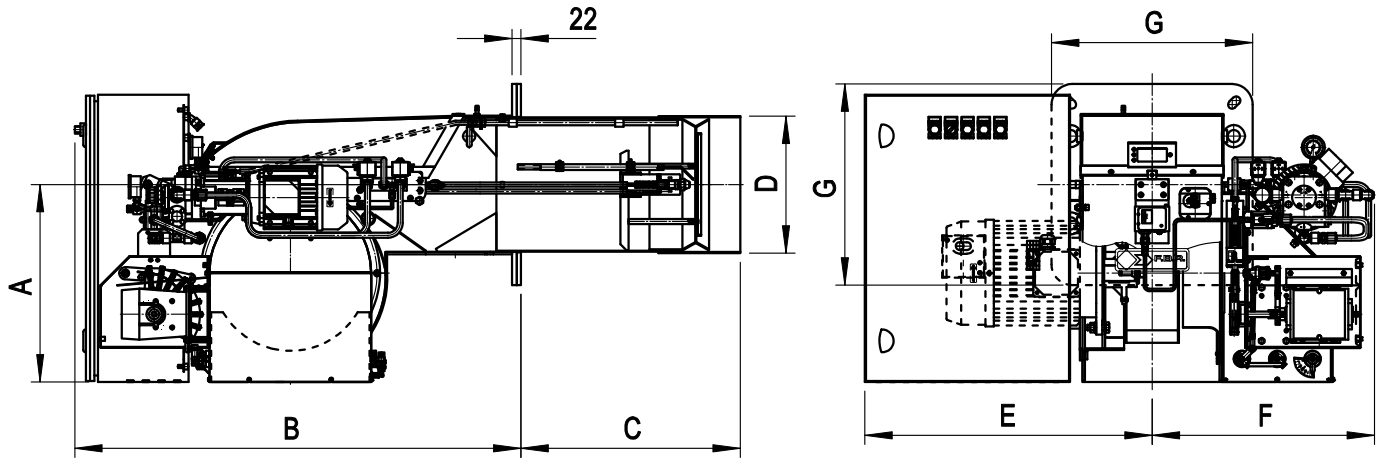
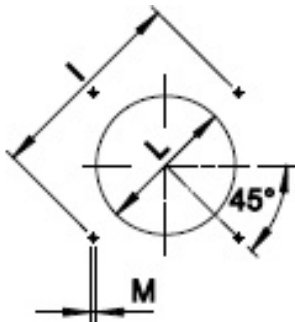

Fig. 3 Dimensions FGP 350/M - FGP 450/M - FGP 550/M

MODEL	A	B	C	D	E	F	G
FGP 350/M	481	1090	535	334	700	540	490
FGP 450/M	481	1090	560	380	700	540	490
FGP 550/M	481	1090	560	380	700	540	490

BOILER PLATE



* Suggested dimension of connection between burner and generator.

Fig. 4 Boiler plate

MODEL		I min	I *	I max	L min	L *	L max	M
FGP 350/M	mm	552	552	580	350	350	450	M14
FGP 450/M	mm	552	552	580	390	390	450	M14
FGP 550/M	mm	552	552	580	390	410	450	M14

PRODUCT SPECIFICATION**SHORT DESCRIPTION**

Light-oil burners two stages progressive (hi-low flame) or modulating (PID fully modulating) if equipped with addition of optional modulation kit and probe.

DETAILED SPECIFICATION

Light-oil burner two stages progressive (hi-low flame) or modulating (PID fully modulating) if equipped with addition of optional modulation kit and probe; composed by:

- Fan at high pressurisation;
- Combustion head with adjustment at high performance and elevated flame stability;
- Flange and insulating gasket for fixing at boiler;
- Three-phase power supply;
- Photoresistance for flame detection;
- IP 40 electric protection level;
- Servomotor for air shutter and for the pressure regulator;
- Easy extraction of combustion head without get off the burners by bolier;
- Maximum light-oil pressure switch to stop the burner in case of the light-oil pressure on the return is higher then the set point value;
- Dedicated motor for the activation of the light-oil pump;
- Set up for the additional specific kit that transforms burner operation as modulating i.e. the modulating kit allows to supply any power between the minimum and the maximum value based on instantaneous loading request.

CONFORMING TO:

- CE rules;
- 2014/30/UE Directive E.M.C.;
- 2014/35/UE Directive L.V.;
- 2014/68/EU Directive M.D.;
- 97/23/CE Directive P.E.D.;
- Reference rules: EN267 (liquid fuel) - EN746-2 (industrial thermoprocessing equipment).

STANDARD EQUIPMENT

- Flexible hoses for connection;
- Line filter;
- Isomart gasket;
- Nozzle;
- Flange with insulating gasket;
- Burner nameplate;
- Warranty;
- Instruction handbook for installation, use and maintenance.

OPTIONAL

- Power modulating kits for temperatures;
- Power modulating kits for pressures;
- Temperature probe 0°C-400°C (PT 100 a 0° C);
- Temperature probe 0°C-1200°C (K probe);
- Pressure probe 0-3 bar, 0-6 bar, 0-16 bar, 0-20 bar, 0-30 bar;
- Noise protection.